

SUBMITTAL SHEET



AIRCONDITIONING PRODUCTS

SYSTEM INDOOR/OUTDOOR
24THS32 THS2432/CH2432
 CEILING SUSPENDED HEAT PUMP

SS24THS32-1

GENERAL DATA (AT 230V)

POWER V/PH/HZ	230/208/1/60
Circuit Ampacity, Min. (A)	30
Fuse size, Max (A)	30

COMPRESSOR	Rotary-Hermetic
No. used	1
R.L. Amps - L.R. Amps (A)	9.4 - 66.0
Crankcase Heater	30W

OUTDOOR FAN - TYPE	Propeller
Dia. (in.) - No. used	18-3/32- 1
Type Drive - No. speeds	Direct ñ 2 (AUTO)
No. Poles - RPM (High)	6 - 879
No. Motors ñ HP	1 - 1/7
CFM (High)	1,840
F.L. Amps. (A)	0.9

OUTDOOR COIL ñ TYPE	Aluminum Fin & Copper Pipe
Fin Type - Pipe Type	Slit Plate - Inner Riffled
Rows - F.P.I.	2- 14.1
Face Area (sq.ft.)	6.78
Tube Size (in.)	3/8

INDOOR FAN ñ TYPE	Centrifugal
Dia. & Length (in.) - No. used	5-1/8 & 4
No. speeds	3 & Auto
No. Poles -RPM (High)	4-1,187
No. Motors - HP	1 - 1/24
CFM (HI/MED/LOW)	540/490/425
F.L. Amps (A)	0.4

INDOOR COIL - TYPE	Aluminum Fin & Copper Pipe
Fin Type - Pipe type	Slit Plate - Inner Riffled
Rows - F.P.I.	3 - 14.9
Face Area (sq. ft.)	1.81
Tube Size (in.)	3/8
Drain Connection Size (in.)	1-1/4

REFRIGERANT	R22
Lbs. - R22 (O.D. Unit)	6.17
Control	Capillary Tube
Connection	Electronic Refrigerant Control Valve
Line Length, Max (ft.)	165
Lift difference, Max (ft.)	100
Line Size - in. O.D. Discharge	1/4
Line Size - in. O.D. Suction	3/4

DIMENSIONS (in.)	H x W x D
Indoor Unit -Uncrated	7- 15/32 x 51- 6/32 x 26-3/8
-Crated	9- 14/32 x 54- 19/32 x 29-31/32
Outdoor Unit-Uncrated	28-15/16 x 37 x 13-3/8
-Crated	32-17/32 x 40 x 16-12/32

WEIGHT	INDOOR	OUTDOOR
Net (lbs.)	60.0	157.0
Shipping(lbs.)	77.0	170.0
Shipping Volume (cu.ft.)	8.9	12.3

PERFORMANCE DATA @ ARI STANDARD CONDITIONS (230/208V)

COOLING		
Total Capacity (BTU/H)		22,400/21,600
Sensible Capacity (BTU/H)		13,640/12,970
Latent Capacity (BTU/H)		8,760/8,630
SEER		10.0/10.0
Dehumidification (Pints/H)		6.3/6.2
Amps (A)		10.7/11.3
Power Inputs (W)		2,290/2,250

HEATING		
Total Capacity (BTU/H)		25,400/25,000
HSPF		7.0/7.0
Amps (A)		11.7/12.9
Power Inputs (W)		2,350/2,280
Back-up Strip Heater (KW)		1.80/1.47
Outdoor Sound Rating(bels)		7.6

FEATURE

Controls	Microprocessor
Remote Controller	LCD Wireless type
Temperature Control	IC Thermostat
Timer	ON/OFF, 24 hours
Night Setback	Built-In
Air Louver (Horizontal)	Manual
(Vertical)	Automatic
Power Failure Automatic Restart	Built-In
Self Diagnosis	N/A

OPTION

Refrigerant Line Set	AP2710BH (30 ft) AP2715BH (50 ft)
Low Ambient Control	Built-In
Fresh Air Intake	N/A
Central Remote ON-OFF Control	Available
Air duct Extension	N/A
Indoor Frame Extension	N/A
Condensate Drain Pump	Available
Non-Removable Remo-con Bracket	RCS5PS4B

OPERATING RANGE

Cooling	Indoor Air Intake Temp.	Outdoor Air Intake Temp.
	Maximum 95F DB/71F WB	115F DB
	Minimum 67F DB/57F WB	23F DB
Heating	Maximum 80F DB/67F WB	75F DB/67F WB
	Minimum -F DB/ - F WB	17F DB/15F WB

CERTIFICATION



Dimensional Data

Indoor Unit: THS2432

Dimension : inch

- ① Drain connection
- ② Drain connection for left side
- ③ Refrigerant liquid line (1/4") Flare connection
- ④ Refrigerant gas line (3/4") Flare connection
- ⑤ Hole for rear side refrigerant tubing
- ⑥ Hole for through-the-wall refrigerant tubing (ø3-15/16" hole)
- ⑦ Hole for fresh air intake (Knockout hole)
- ⑧ Hole for right side refrigerant tubing (Knockout hole)
- ⑨ Hole for left side drain connection (Knockout hole)
- ⑩ Hole for power supply (Conduit size 1/2")
- ⑪ Infrared rays receiver for wireless remote controller
- ⑫ Cutting position for fresh air intake

1919_THS_1

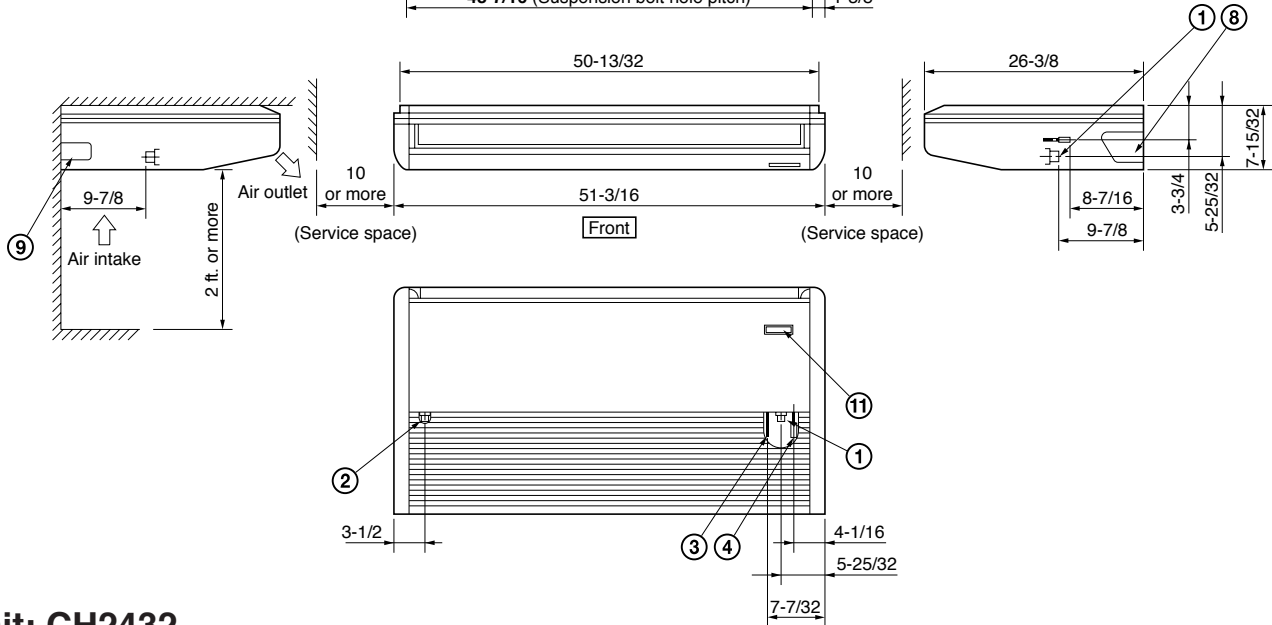
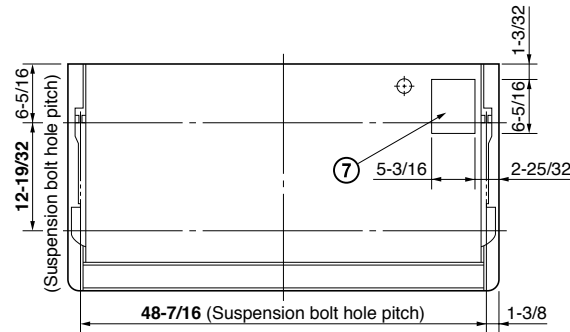
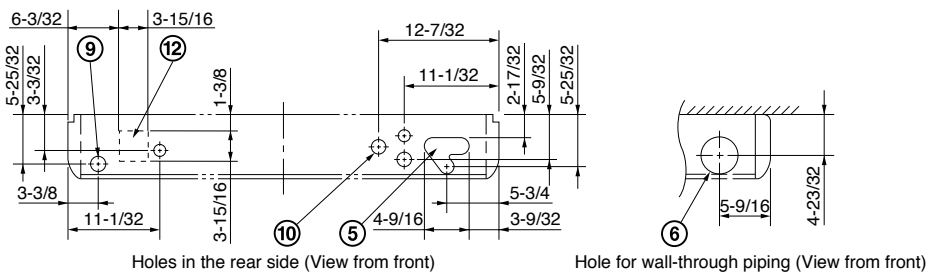

Outdoor Unit: CH2432

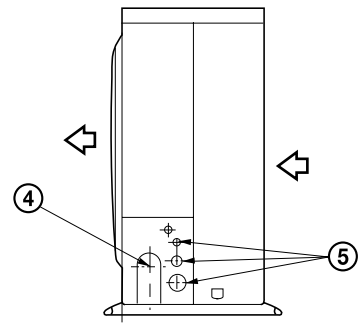
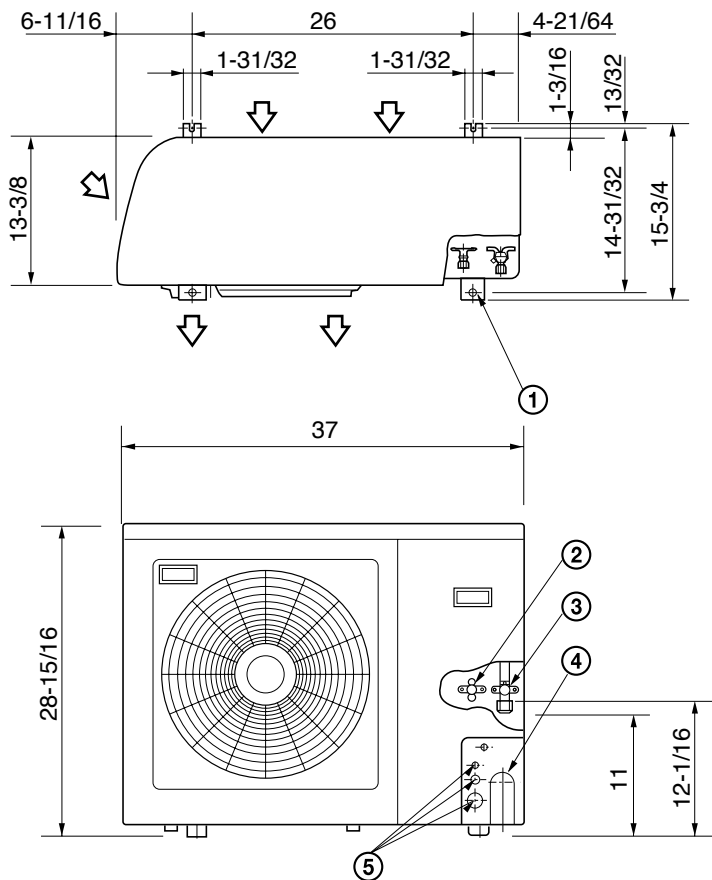

Dimension : inch

- ① Hole for anchor bolt (4-ø1/2)
- ② Refrigerant tube joint (narrow tube) Flare connection 1/4 in (6.35 mm)
- ③ Refrigerant tube joint (wide tube) Flare connection 3/4 in (19.05 mm)
- ④ Refrigerant tubing inlet
- ⑤ Power supply inlet

1131_THS_1

WARRANTY

SANYO products are warranted against defects in materials and workmanship for the period below;

	LABOR	PARTS
Compressor	30 Days	5 Years
Other Components	N/A	1 Year

Because of a policy of continuous product improvements, SANYO reserves the right to change specifications and design without notice.

Full specific warranty rights, conditions, exclusions and obligations are specified in the warranty packed with each products.

SANYO FISHER COMPANY

A Division of SANYO North America Corporation

21605 Plummer St. Chatsworth, CA 91311

Phone : (818) 998-7322

Fax : (818) 701-4160

Website: <http://www.sanyohvac.com>